



**Installation,
Operation
&
Maintenance
Manual**

Welker[®] Instrument Regulators

Models

IR-1

IR-2

IR-4

IR-6

The information in this manual has been carefully checked for accuracy and is intended to be used as a guide for the installation, operation, and maintenance of the Welker equipment described above. Correct operating and/or installation techniques, however, are the responsibility of the end user. Welker reserves the right to make changes to this and all products to improve performance and reliability.

13839 West Bellfort
Sugar Land, Texas 77498-1671
U.S.A.

Tel.: (800) 776-7267

Tel.: (281) 491-2331

Fax: (281) 491-8344

www.welkereng.com

This page intentionally left blank

TABLE OF CONTENTS

1. GENERAL	4
1.1 Introduction.....	4
1.2 Product description.....	4
1.3 Specifications	5
2. INSTALLATION & OPERATION INSTRUCTIONS	7
2.1 General.....	7
2.2 Installing the regulator	7
2.3 Setting the regulator	7
3. MAINTENANCE INSTRUCTIONS	9
3.1 General.....	9
3.2 Upper housing maintenance.....	10
3.3 Lower housing maintenance.....	11

Welker®, Welker Jet®, and WelkerScope® are Registered Trademarks owned by Welker.

INTRODUCTION

1. GENERAL

1.1 Introduction

We appreciate your business and your choice of Welker products. The installation, operation, and maintenance liability for this product becomes that of the purchaser at the time of receipt. Reading the applicable *Installation, Operation, and Maintenance (IOM) Manual* prior to installation and operation of this equipment is required for a full understanding of its application and performance prior to use. If you have any questions, please call 1-800-776-7267 in the USA or 1-281-491-2331.

The following procedures have been written for use with standard Welker parts and equipment. Assemblies that have been modified may have additional requirements and specifications that are not listed in this manual.

Notes, Warnings, and Cautions



NOTE

Notes emphasize information or set it off from the surrounding text.



CAUTION

Caution messages appear before procedures that, if not observed, could result in damage to equipment.



WARNING

Warnings alert users to a specific procedure or practice that, if not followed correctly, could cause personal injury.

1.2 Product description

The Welker Instrument Regulators (IR-6, IR-4, IR-2 & IR-1 series) are designed to provide an adequate output pressure for devices that are unable to sustain high pressures. Pressure is reduced as it travels from the regulator's inlet port to its outlet port. In order to set the desired output pressure, an adjusting screw on the device is tightened, pushing down on a spring inside the device. The spring then pushes down on a piston or diaphragm, which, in turn, pushes against a poppet. When high pressure is applied to the regulator's inlet port, the poppet is moved up, allowing only the set amount of pressure to pass through the device.

In addition to the inlet port, the instrument regulator has three common ports on the body: the gauge, relief, and outlet. All ports are marked on the device accordingly. The IR-6, IR-2 and IR-1 series regulators are equipped with a piston, while the IR-4 is equipped with a diaphragm (see Figures 1 and 2). If the regulator is bolted together, it has a piston assembly.



NOTE

Model *IR-1T* is the exception, as it has a diaphragm and is bolted together.

SPECIFICATIONS

1.3 Specifications

N NOTE

The specifications listed in this section are generalized for this equipment. Welker can modify the equipment according to your company's needs. However, please note that **the specifications may vary depending on the customization of your product.**

Diaphragm Assembly

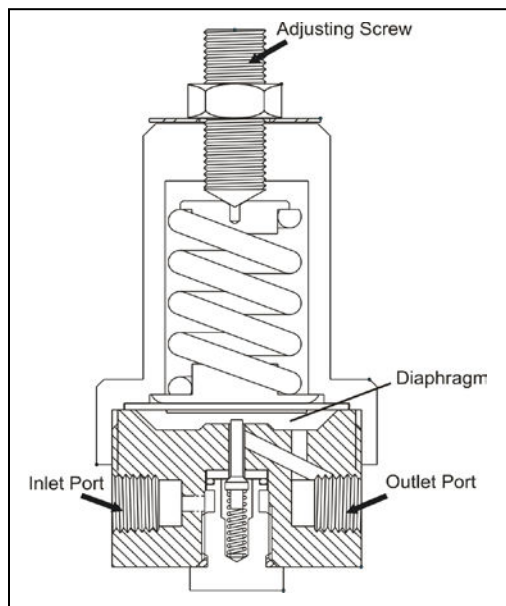

Figure 1

Piston Assembly

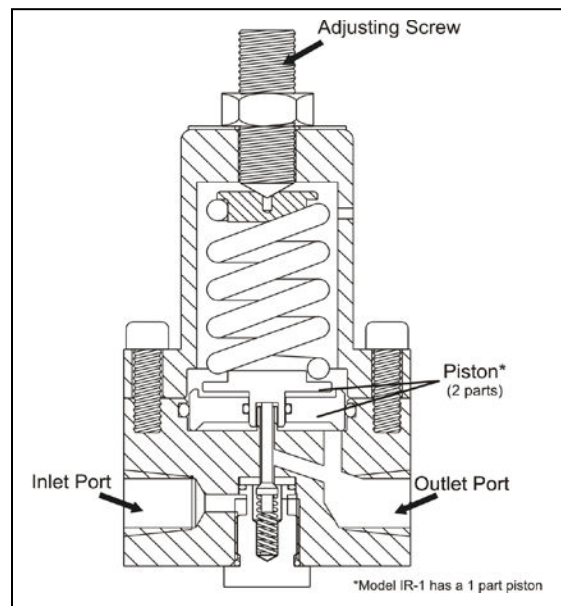

Figure 2

N NOTE

For clarity, only the inlet and outlet ports are shown.

SPECIFICATIONS

Specifications	
Products	Gaseous fluids or liquids compatible with the materials of construction.
Materials of Construction	316 Stainless Steel, Viton [®] , PTFE, Buna-N [®] , and Kel-f [®] (others available)
Sample Outlet Connection	1/4" NPT (others available)
Sample Inlet Connection	1/4" NPT (others available)
Auxiliary Connections	1/4" NPT
Maximum Allowable Inlet Pressure	IR-6 IR-2 IR-1: 5,000 psi @ -20° F to 100 ° F (344 bar @ -29° C to 37° C) IR-4: 3,600 psi @ -20° F to 100 ° F (248 bar @ -29° C to 37° C)
Output Range	IR-6: 250-1,500 psi @ -20° F to 100 ° F (17-103 bar @ -29° C to 37° C) IR-2: 0-500 psi @ -20° F to 100 ° F (0-34 psi @ -29° C to 37° C) IR-1: 0-200 psi @ -20° F to 100 ° F (0-13 psi @ -29° C to 37° C) IR-4: 0-200 psi @ -20° F to 100 ° F (0-13 bar @ -29° C to 37° C)

Table 1

INSTALLATION & OPERATION

2. INSTALLATION & OPERATION INSTRUCTIONS

2.1 General

After unpacking the unit, check it for compliance and for any damages that may have occurred during shipment.

N NOTE

Claims for damages caused during shipping must be initiated by the receiver and directed to the shipping carrier. Welker is not responsible for any damages caused from mishandling by the shipping company.

N NOTE

When sealing fittings with PTFE tape, refer to the proper sealing instructions for the tape used.

2.2 Installing the regulator

- 2.2.1 Connect a gauge to the gauge port on the regulator.
- 2.2.2 Connect a relief valve to the relief valve port on the regulator.
- 2.2.3 Use tubing to connect the inlet supply to the inlet port on the regulator.

W WARNING

Do not turn on the inlet supply at this time. Turning on the inlet supply before the relief valve is set could result in over pressurizing the regulator.

N NOTE

Welker recommends installing an upstream filter if the product has solid particles. The filter should be installed on the connection to the regulator inlet.

- 2.2.4 Use tubing to connect from the outlet port on the regulator to the inlet of the instrument.

2.3 Setting the regulator

- 2.3.1 Use a safe auxiliary gas supply to set the relief valve to the proper pressure (*refer to IO&M for relief valve*).

W WARNING

If you choose to use the regulator to set the relief, do not exceed the output pressure range of the device.

N NOTE

If requested, the manufacturer can preset the relief prior to shipment.

INSTALLATION & OPERATION

- 2.3.2 Turn on the inlet supply to pressurize the regulator inlet.
- 2.3.3 Loosen or tighten the adjusting screw until the gauge reads the desired pressure for outlet (see Figure 3).

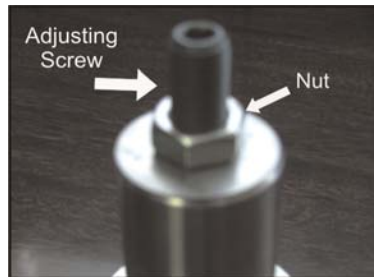

Figure 3

- 2.3.4 Tighten the nut on the adjusting screw to secure it into place.
- 2.3.5 Check the entire system for leaks.
- 2.3.6 The regulator is now in operation.

3. MAINTENANCE INSTRUCTIONS

3.1 General

Prior to maintenance or disassembly of the unit, it is advisable to have a repair kit handy for the system in case of encountering unexpected wear or faulty seals. All maintenance and cleaning of the unit should be done on a smooth, clean surface.

N NOTE

We recommend that the unit have annual maintenance under normal operating conditions. In the case of severe service, dirty conditions, excessive cycling usage, or other unique applications that may subject the equipment to unpredictable circumstances, a more frequent maintenance schedule may be appropriate.

N NOTE

New seals supplied in spare parts kits are not lubricated. They should be lightly coated with lubrication grease (Dow Corning 111 [DC 111] or equivalent lubricant) before they are installed into the equipment. This helps with the installation of the seals while reducing the risk of damage when positioning them on the parts.

! CAUTION

Maintenance on the instrument regulator should not be performed until the regulator has been isolated from all pressure.

Recommended Tools

It would be advisable to have the following tools available for installation of the unit. However, tools used will vary depending on model.

- 3/16" Allen wrench
- 1/4" Allen wrench
- 6" adjustable wrench
- Small screwdriver
- Small, pointed instrument

MAINTENANCE

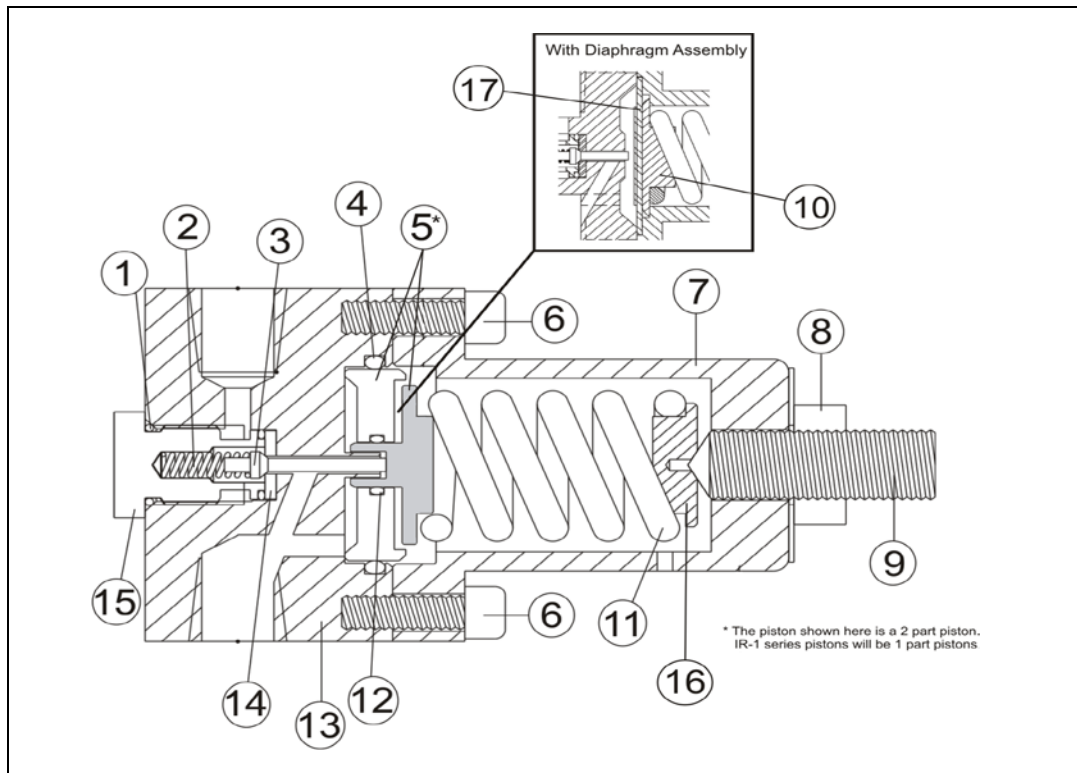

Figure 4

Refer to this figure throughout the entire maintenance process.

Part No.	Description	Part No.	Description
1	Seal	2	Poppet Spring
3	Poppet	4	O-Ring
5	Piston	6	Socket Screws
7	Spring Housing	8	Adjusting Nut
9	Adjusting Screw	10	Bottom Spring Guide
11	Spring	12	O-Ring
13	Regulator Body	14	Seat
15	Flow Ring	16	Top Spring Guide
17	Diaphragm		

3.2 Upper housing maintenance

- 3.2.1 Turn off the inlet supply pressure to the regulator inlet.
- 3.2.2 Disconnect the inlet supply from the regulator inlet port.
- 3.2.3 Disconnect the instrument from the regulator outlet port

- 3.2.4 Loosen the nut (Part 8) on the adjusting screw (Part 9).
- 3.2.5 Loosen the adjusting screw to relieve tension on the spring (Part 11).
- 3.2.6 **Disassemble Piston Assembly** (if you have a regulator with a diaphragm, please continue to step 3.2.7):



NOTE

If the regulator is bolted together, it has a piston assembly.

- a) Remove the eight socket head screws (Part 6) and remove the spring housing (Part 7).
- b) Remove the spring guide (Part 16) and the spring (Part 11).
- c) **Carefully** remove the piston (Part 5) without scratching it.
- d) Replace both O-ring seals (Parts 4 and 12) in the piston body.
- e) Inspect the sealing surfaces of the piston for scratches.
- f) Push the piston back into place. Continue to step 3.2.8.

3.2.7 Disassemble Diaphragm Assembly:

- a) Unscrew the spring housing (Part 7) and remove.
- b) Remove the top spring guide (Part 16) and the spring (Part 11).
- c) Remove the bottom spring guide (Part 10).
- d) Remove the diaphragm (Part 17). Inspect for wear, and replace if necessary.
- e) Set the diaphragm back into place.
- f) Set the bottom spring guide back into place on top of the diaphragm. Continue to step 3.2.8.

3.2.8 Set the spring (Part 11) back into place.

3.2.9 Set the top spring guide (Part 16) back into place on top of the spring.

3.2.10 Reattach the spring housing (Part 7) securely. For the IR-4 series regulators, hand-tighten the housing. For the IR-1, 2, and 6 series, cross-bolt the eight socket head screws (Part 6).

3.3 Lower housing maintenance

3.3.1 Unscrew the flow ring (Part 15) from the regulator body (Part 13) (also see Figure 5).



Figure 5

3.3.2 Replace the seal (Part 1) on the flow ring.

3.3.3 Remove the poppet spring (Part 2) and the poppet (Part 3) (also see Figure 6).

MAINTENANCE

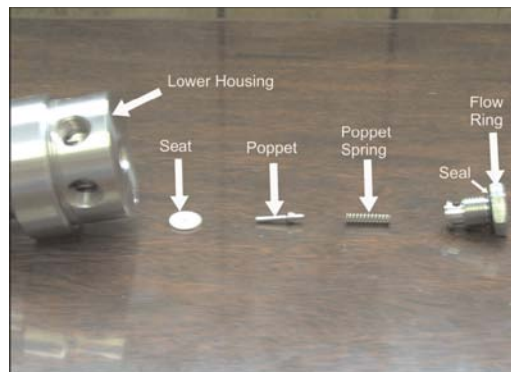

Figure 6

- 3.3.4 Examine the poppet and poppet spring. Replace if necessary.
- 3.3.5 Use a pointed instrument to carefully pick the seat (Part 14) out of the body.
- 3.3.6 Examine the seat and replace if necessary.
- 3.3.7 Set the seat back into place.

N NOTE

Debris or scratches on either the poppet or seat will prevent positive shut off of the regulator.

- 3.3.8 Guide the poppet into the seat.
- 3.3.9 Reattach the poppet spring and flow ring.
- 3.3.10 Tighten the flow ring securely.
- 3.3.11 The unit is now ready for reinstallation.

This page intentionally left blank.



13839 West Bellfort, Sugar Land, Texas 77498-1671

Phone: (281) 491-2331

Fax: (281) 491-8344

Toll Free: (800) 776-7267

Web Page: www.welkereng.com